

HU365

Safety switch, heavy duty, non fusible, 400A, 3 poles, 350 hp, 600 VAC/DC, NEMA1

Product availability : Stock - Normally stocked in distribution facility



Main

Product	Single Throw Safety Switch
Duty Rating	Heavy duty
Device application	Heavy application
Disconnect Type	Non-fusible disconnect
Factory Installed Neutral	None
Phase	3 phase
Number of Poles	3
Current Rating	400 A
Voltage Rating	600 V AC/DC
Enclosure Rating	NEMA 1 steel
Maximum Horse Power Rating	125 hp 240 V at AC 50-60 Hz for 3 phase conforming to NEC 430.52 250 hp 480 V at AC 50-60 Hz for 3 phase conforming to NEC 430.52 350 hp 600 V at AC 50-60 Hz for 3 phase conforming to NEC 430.52 50 hp 250 V at DC 50 hp 600 V at DC

Complementary

Short Circuit Current Rating	200 kA maximum
Mounting Type	Surface
Electrical Connection	Lugs
Wiring configuration	3-wire
Wire Size	AWG 1/0...750 kcmil copper or aluminium
Tightening torque	550 lbf.in (62.14 N.m) AWG 1/0...750 kcmil)
Depth	10.13 in (257.30 mm)
Width	27.63 in (701.80 mm)
Height	50.25 in (1276.35 mm)

* Price is "List Price" and may be subject to a trade discount – check with your local distributor or retailer for actual price.

Net Weight	169.98 lb(US) (77.1 kg)
------------	-------------------------

Environment

Certifications	UL listed file E2875
----------------	----------------------

Ordering and shipping details

Category	00053 - H&HU SW,NEMA1,400-1200A
Discount Schedule	DE1
GTIN	00785901787303
Nbr. of units in pkg.	1
Package weight(Lbs)	170 lb(US) (77.11 kg)
Returnability	Yes
Country of origin	MX

Packing Units

Unit Type of Package 1	PCE
Package 1 Height	14.29 in (36.3 cm)
Package 1 width	28.31 in (71.9 cm)
Package 1 Length	52.01 in (132.1 cm)

Offer Sustainability

Sustainable offer status	Green Premium product
California proposition 65	WARNING: This product can expose you to chemicals including: Lead and lead compounds, which is known to the State of California to cause cancer and birth defects or other reproductive harm. For more information go to www.P65Warnings.ca.gov
REACH Regulation	REACH Declaration
REACH free of SVHC	Yes
EU RoHS Directive	Compliant EU RoHS Declaration
Mercury free	Yes
RoHS exemption information	Yes
China RoHS Regulation	China RoHS declaration Product out of China RoHS scope. Substance declaration for your information.
Environmental Disclosure	Product Environmental Profile
PVC free	Yes
Halogen content performance	Halogen free plastic parts product

Contractual warranty

Warranty	18 months
----------	-----------

Approximate Dimensions

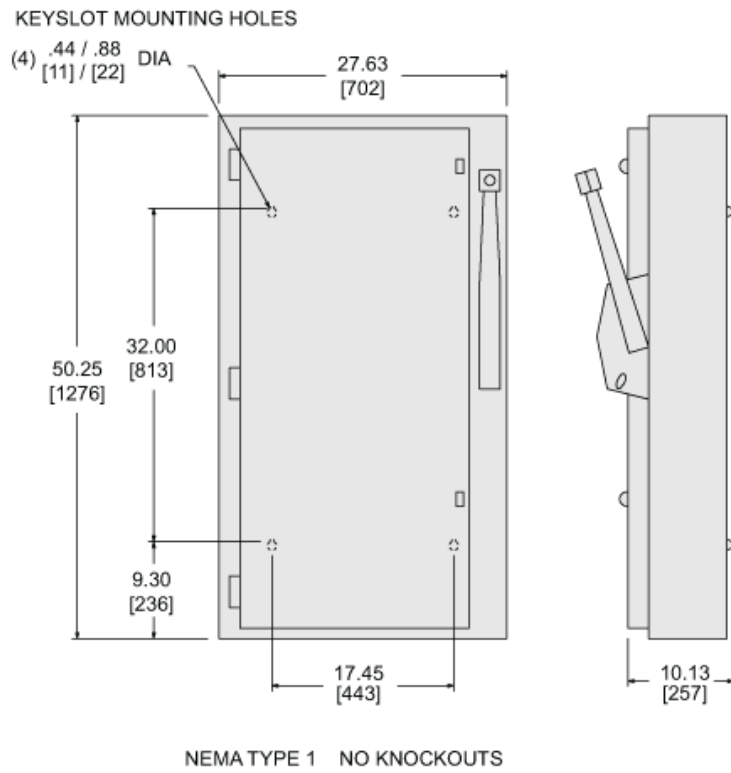

Wiring Diagrams

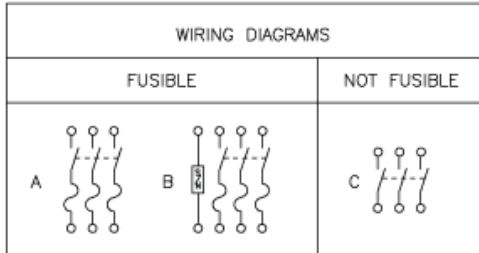

NOTE: FOR SWITCHING DC USE TWO OUTSIDE POLES.

TERMINAL LUGS DATA			
AMPERES	MAX WIRE	MIN WIRE	TYPE
400	(1) 750 KCMIL OR (2) 300 KCMIL	(1) #1/0 AWG OR (2) #1/0 AWG	AL OR CU

CATALOG NUMBER	MAX VOLTAGE RATINGS	WIRING DIAG	HORSEPOWER RATINGS						
			240VAC		480VAC		600VAC		
			MAX	STD	MAX	STD	MAX	250 VDC	600 VDC
H365	600VAC;600VDC	A	-	100	250	125	350	50	50
H365N	600VAC;600VDC	B	-	100	250	125	350	50	50
HU365	600VAC;600VDC	C	125	-	250	-	350	50	50